

# Pins preheating furnace

## Description

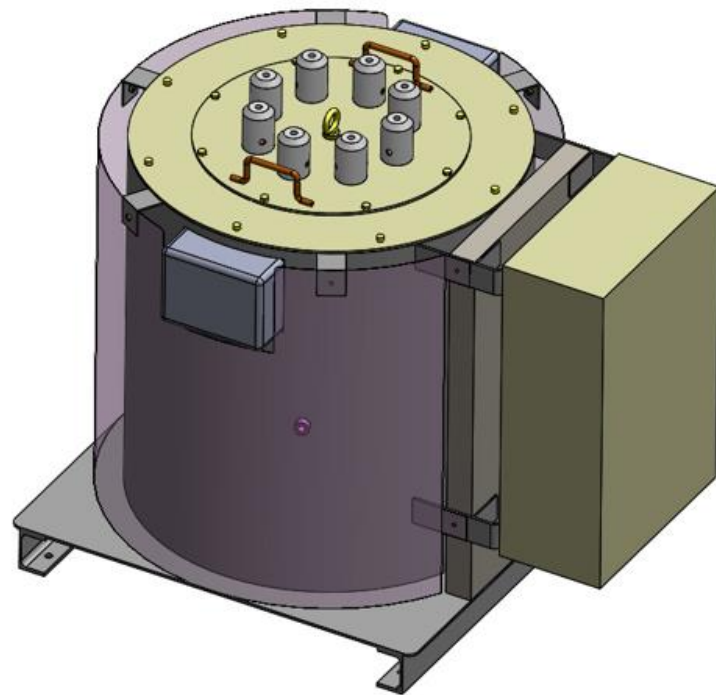

- Heating box for pins associated with its control cabinet
- Total power : 2 x 4kW
- Maximum temperature: 600°C
- Stainless steel internal structure
- Power supply : 230V mono

## How to use It

- Preheating of pins for vertical casting spouts
- 4 to 12 pins depending on the model

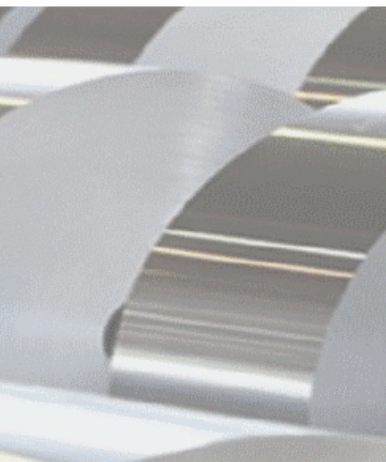
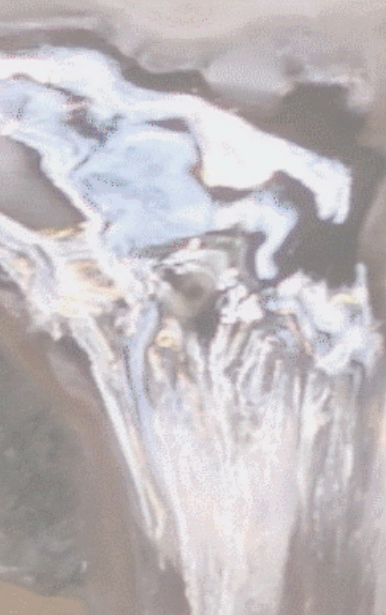
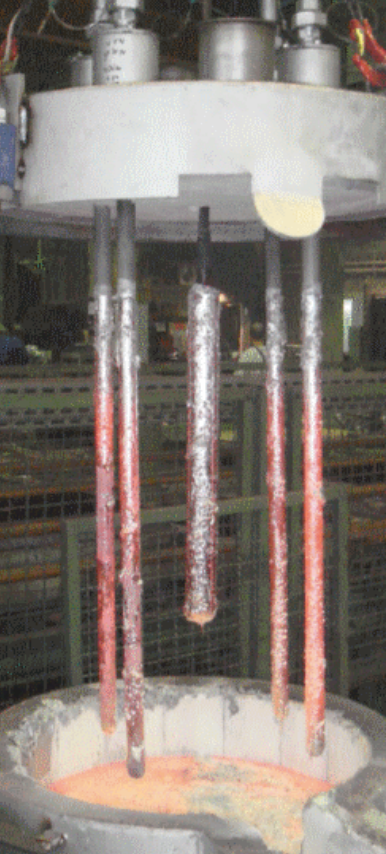
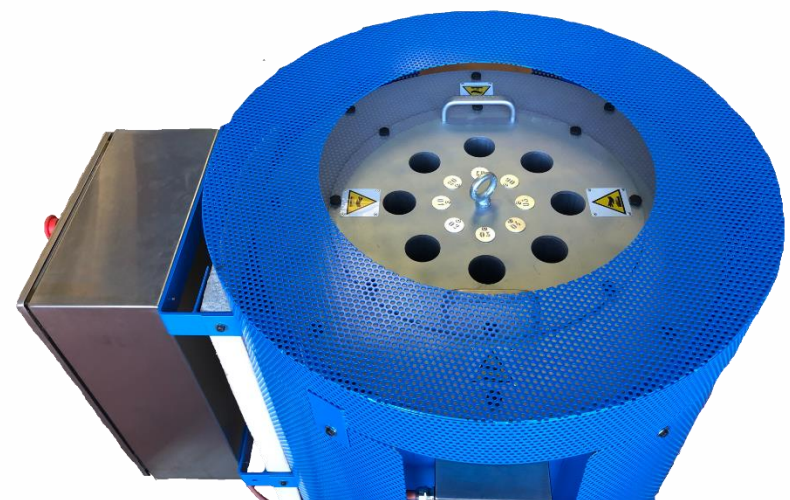



# Chauffe Quenouilles

## Description

- Caisson chauffant pour quenouilles associé à son armoire de pilotage
- Puissance totale : 2 x 4kW
- Température maximum : 600°C
- Structure interne en acier Inoxydable
- Alimentation : 230V mono

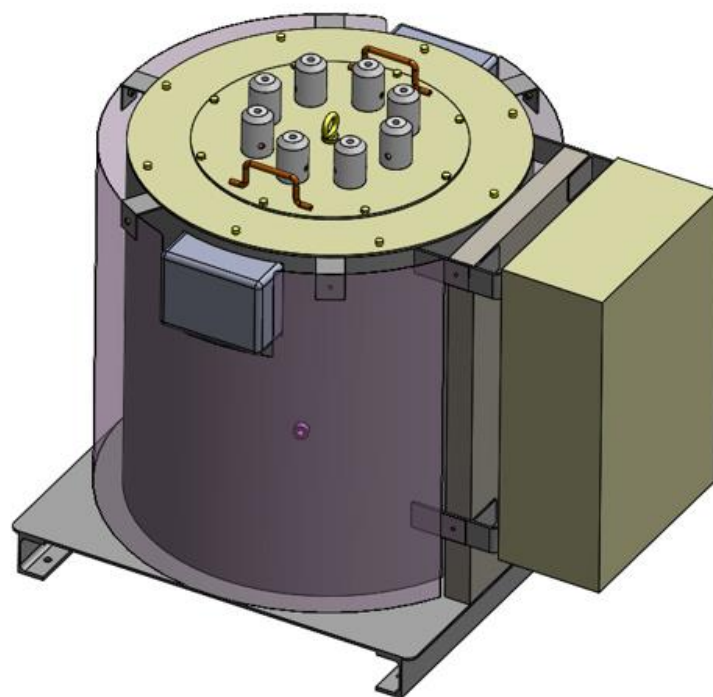

## Utilisation

- Préchauffage de quenouilles pour goulottes de coulée
- 4 à 12 quenouilles selon les modèles

