

Loop Heat Pipe and thermal connector

Description

A Loop heat Pipe is associated with a thermal connector for on-board rackable electronic application

Use cases

- Long distances between hot spot and cold source (500 mm)
- Can ascend more than 400mm against gravity
- Thermal device is attached with rackable card and disconnected as electronic slots

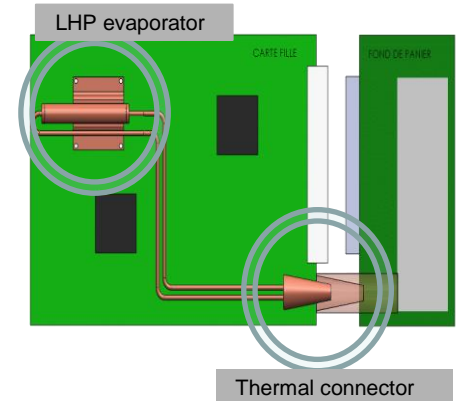

Examples

